



Killeshal Precast Concrete Ltd
 Dsingingain, Co. Offaly, Ireland

Tel: +353 57 9353018

Fax: +353 57 9353272

E-Mail: sales@killeshal.com

Web: www.killeshal.com

S/255

Type H Sill

Doc Ref:-Kilform 286/04/08 Rev Lvl 7

Drawn By DON 07/07/2014 Approved By

Approx Weight 60 Kgs/M P.N. 07/07/14

Note: All Vertical Faces Would Typically have a Taper of 4 mm in 100 mm.

All dimensions as per drawing and allowable tolerances		Bolts as per specification and drawing		Quantity as per order		Welding visually correct	
Number of moulds accepted	Number of moulds Rejected	Reason for rejection			Date	Checkers initials	

Moulds:-

- 3 Single Moulds @ 2500mm
- 4 No Gang Moulds x 6 Runs.
- 4 @ 760 x 760 mm (90 Deg Ext.)
- 2 @ 2000 mm L.H. (90 Deg Ext Return End.)
- 2 @ 2000 mm R.H. (90 Deg Ext Return End.)
- 2 @ 2000 x 160 mm L.H. (135 Deg Ext.)
- 2 @ 2000 x 160 mm R.H. (135 Deg Ext.)
- 2 @ 760 x 760 mm (135 Deg Ext.)

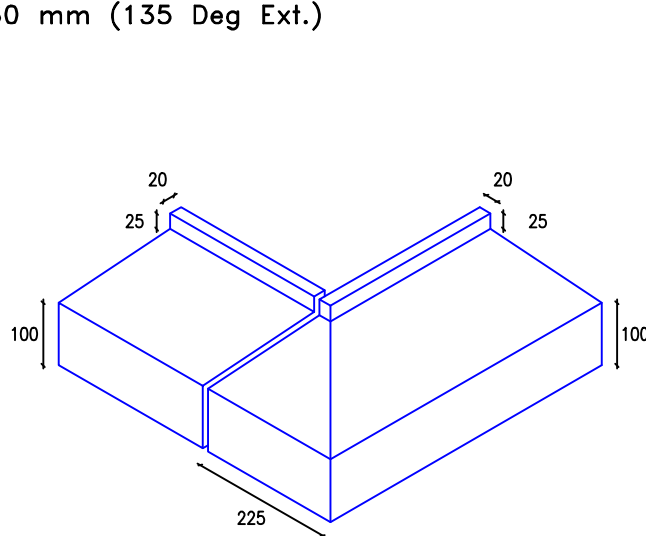

Details of L.H. (90 Deg Ext Return End.)

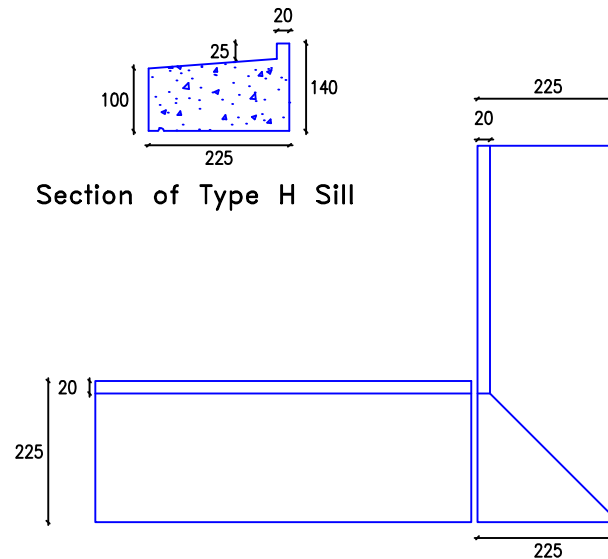

Section of Type H Sill

Scale (N.T.S)