

Doc Ref:-Kilform 286/04/08		Rev Lvl 7
Drawn By	DON	29/09/2014
Approved By		
Approx Weight	60 Kgs/M	P.N. 29/09/14

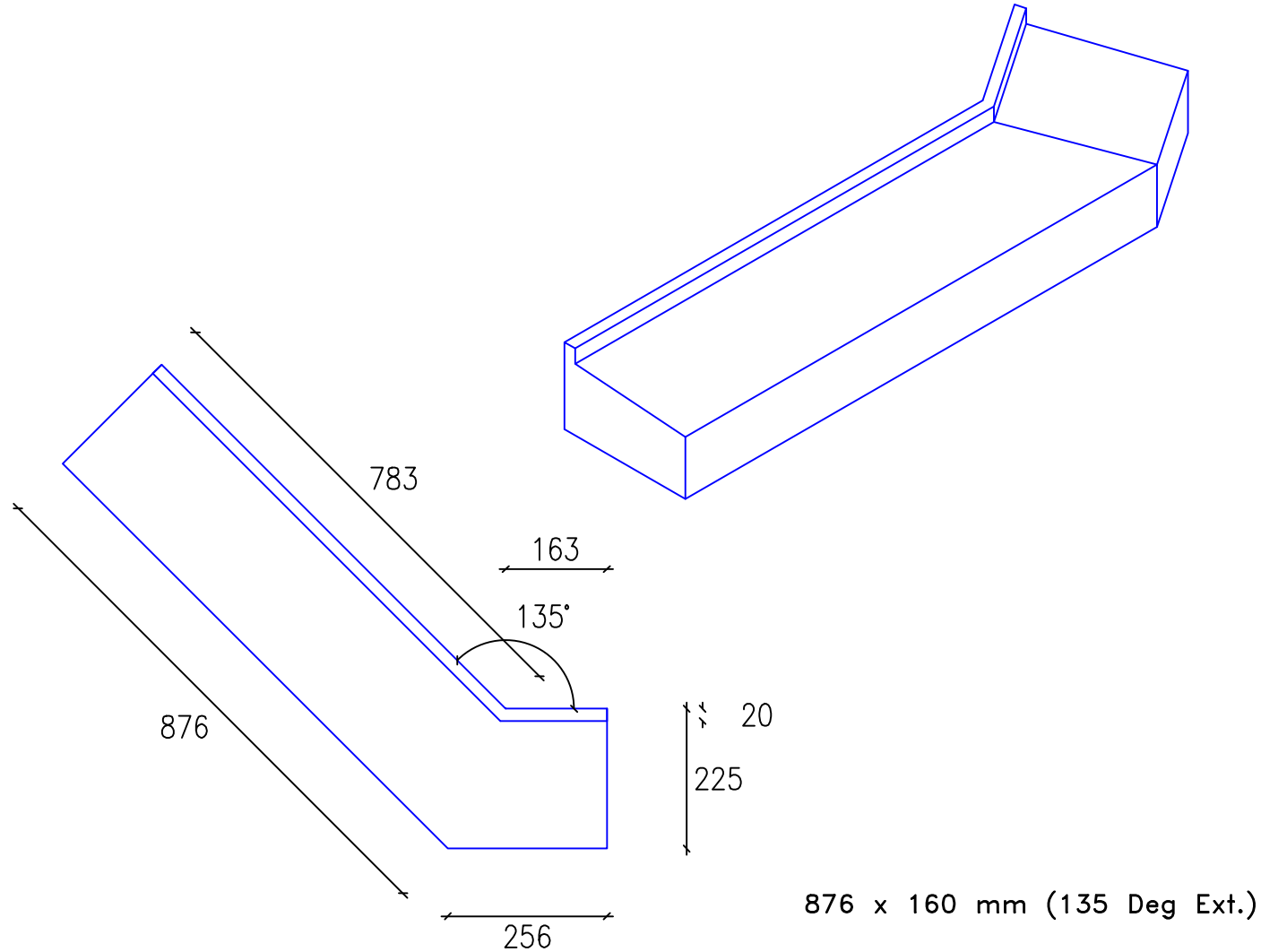

Note: All Vertical Faces Would Typically have a Taper of 4 mm in 100 mm.

All dimensions as per drawing and allowable tolerances		Bolts as per specification and drawing		Quantity as per order		Welding visually correct	
Number of moulds accepted	Number of moulds Rejected	Reason for rejection	Date	Checkers initials			



Scale (N.T.S)